

**SERIES: C14 | DESCRIPTION: PANEL MOUNT ENCODER**
**FEATURES**

- 2-bit quadrature output
- compact
- rugged metal design
- 1 million cycle life
- multiple termination options
- IP65 rating option

**ELECTRICAL**

parameter	conditions/description	min	typ	max	units
power supply	3.3Vdc input models	3.168	3.3	3.432	Vdc
	5Vdc input models	4.75	5	5.25	Vdc
supply current	3.3Vdc input models			40	mA
	5Vdc input models			20	mA
output	open collector				
output code	2-bit quadrature, channel A leads channel B by 90° with clockwise rotation				
power consumption	3.3Vdc input models			132	mW
	5Vdc input models			100	mW
output resolution	4 ppr (16 cpr), 8 ppr (32 cpr)				
angle of throw	16 detent position models		22.5		°
	32 detent position models		11.25		°

**PUSH SWITCH SPECIFICATIONS**

parameter	conditions/description	min	typ	max	units
rating	12 Vdc at 50 mA				
contact resistance				200	mΩ
isolation voltage	for 1 minute		250		Vac
insulation resistance		100			MΩ
operating push force		3.5	4.5	5.5	N
travel		0.2	0.5	0.8	mm
bounce				10	ms
push switch life			1,000,000		cycles

**ENVIRONMENTAL**

parameter	conditions/description	min	typ	max	units
operating temperature		-10		70	°C
storage temperature		-20		80	°C
vibration	10~55Hz with a peak to peak amplitude of 1.5mm				
shock	half sine wave for 11ms		50		G
cold test	at -20°C for 96 hours				
heat test	at +80°C for 96 hours				

## ENVIRONMENTAL (CONTINUED)

parameter	conditions/description	min	typ	max	units
temperature change test	at -10~70°C for 30 minutes each				
humidity test	at 40°C, 90~95% humidity for 96 hours				
RoHS	2011/65/EU				

## MECHANICAL

parameter	conditions/description	min	typ	max	units
shaft load	radial			10	N
	axial			15	N
operational torque	without detent	0.2	0.4	0.2	N·cm
	with detent			0.6	N·cm
mounting torque			100		N·cm
rotational life			1,000,000		cycles
weight			11		g

## OUTPUT WAVEFORMS

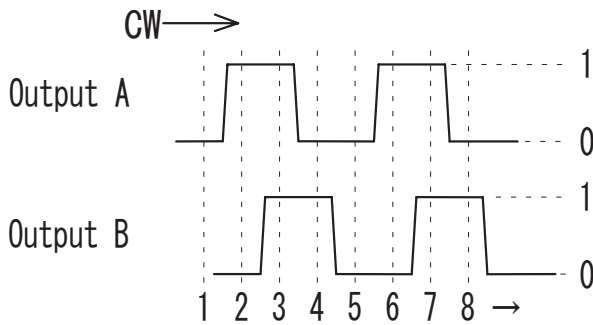

Position	1	2	3	4	5
Output A	0	1	1	0	0
Output B	0	0	1	1	0

(1) 3.3V : "0":0.8V max. "1":2.3V min.

(2) 5V : "0":1.0V max. "1":3.0V min.

\*The code repeats from 1 to 4.

## PART NUMBER KEY

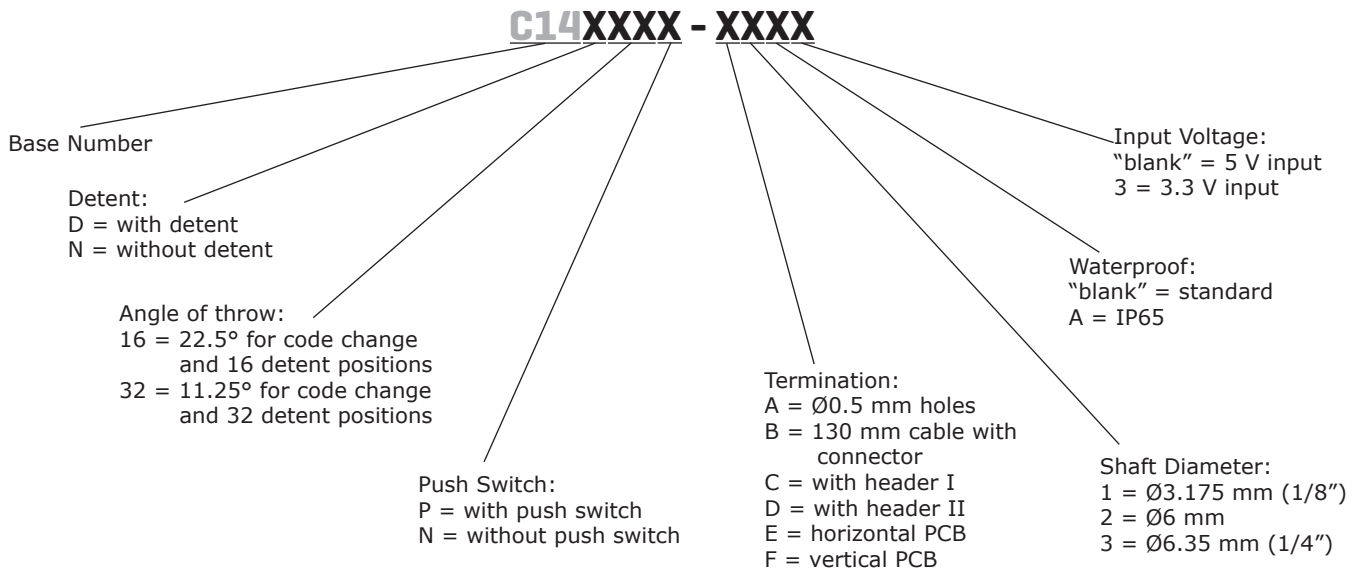

## OUTPUT CIRCUIT

### 5V Input

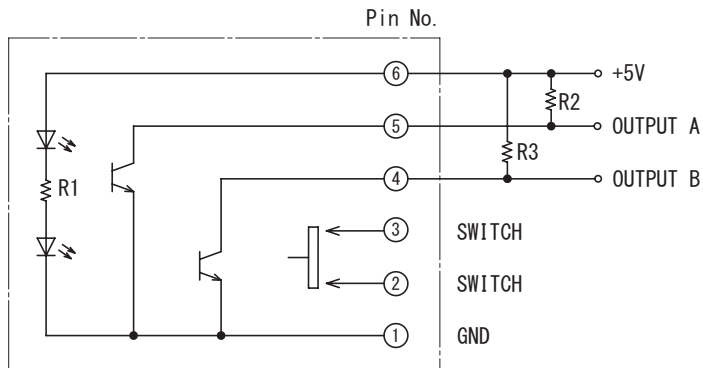

\* R2, R3: External pull-up resistors 5.1K $\Omega$

### 3.3V Input



\* R3, R4: External pull-up resistors 5.1K $\Omega$

## MECHANICAL DRAWING

### 5V INPUT, WITH PUSH SWITCH

units: mm



### Ø6.0mm Shaft



### Mounting Hole Dimensions

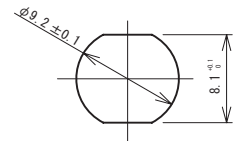

### Ø6.35mm Shaft

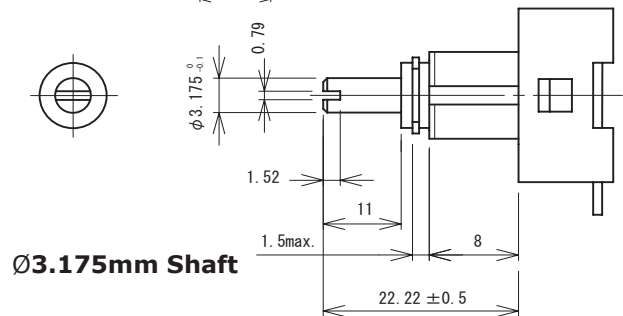

### Ø3.175mm Shaft

## MECHANICAL DRAWING (CONTINUED)

### 5V INPUT, WITHOUT PUSH SWITCH

units: mm



### 3.3V INPUT, WITH PUSH SWITCH

units: mm



## MECHANICAL DRAWING (CONTINUED)

### 3.3V INPUT, WITHOUT PUSH SWITCH

units: mm



## MECHANICAL DRAWING, TERMINATION OPTIONS

units: mm

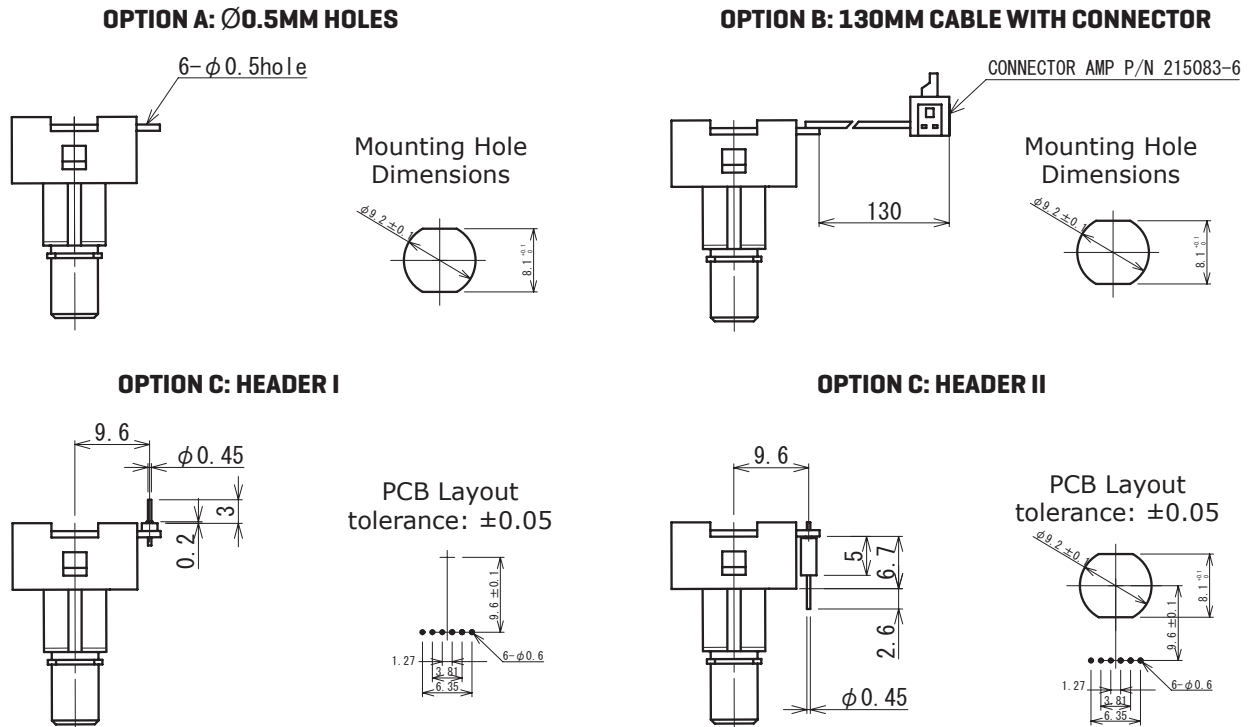

## MECHANICAL DRAWING, TERMINATION OPTIONS (CONTINUED)

units: mm

### OPTION E: HORIZONTAL PCB

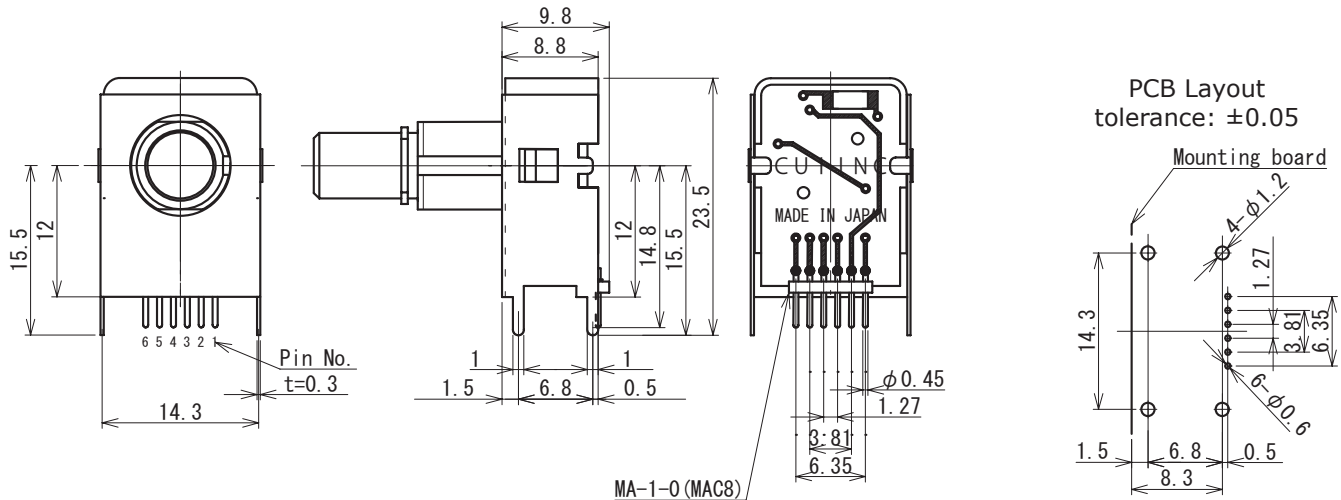

### OPTION F: VERTICAL PCB

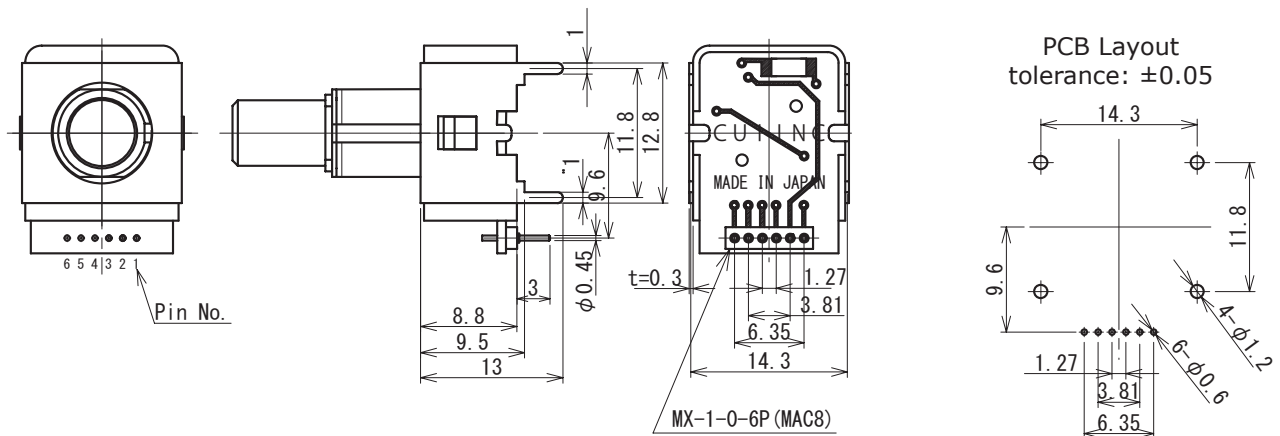

## WATERPROOF MOUNTING

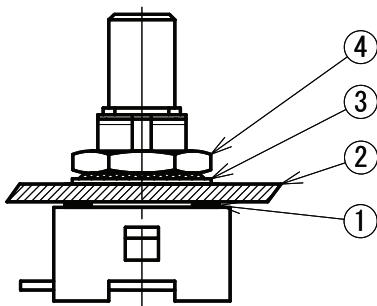

No.	Qty.	Component
1	1	waterproof washer
2	1	panel
3	1	toothed lock washer
4	1	nut

Note: 1. Protects against ingress of water (IP65) from front side of panel only.

## REVISION HISTORY

rev.	description	date
1.0	initial release	02/25/2009
1.01	applied new spec template, updated operating temperature, updated 3.3V PCB	05/20/2014

The revision history provided is for informational purposes only and is believed to be accurate.



**CUI INC**<sup>®</sup>

**Headquarters**  
20050 SW 112th Ave.  
Tualatin, OR 97062  
**800.275.4899**

Fax 503.612.2383  
**cui.com**  
techsupport@cui.com

CUI offers a one (1) year limited warranty. Complete warranty information is listed on our website.

CUI reserves the right to make changes to the product at any time without notice. Information provided by CUI is believed to be accurate and reliable. However, no responsibility is assumed by CUI for its use, nor for any infringements of patents or other rights of third parties which may result from its use.

CUI products are not authorized or warranted for use as critical components in equipment that requires an extremely high level of reliability. A critical component is any component of a life support device or system whose failure to perform can be reasonably expected to cause the failure of the life support device or system, or to affect its safety or effectiveness.